

## Rope Tension Transducer (RTT)

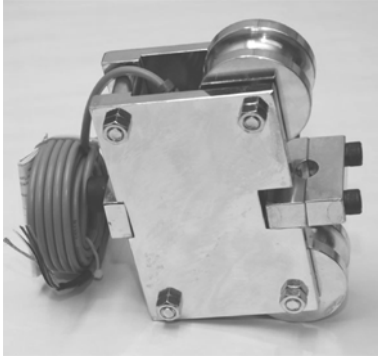

### FEATURES

- Easy mounting
- Rope and Wire overload control

### DESCRIPTION

Clamp on module for rope and wire forces measurement.  
Easy to install, overload protection for cranes.

### APPLICATIONS

- Overload alarm
- Force over load measurement
- Cranes

### OUTLINE DIMENSIONS IN MM

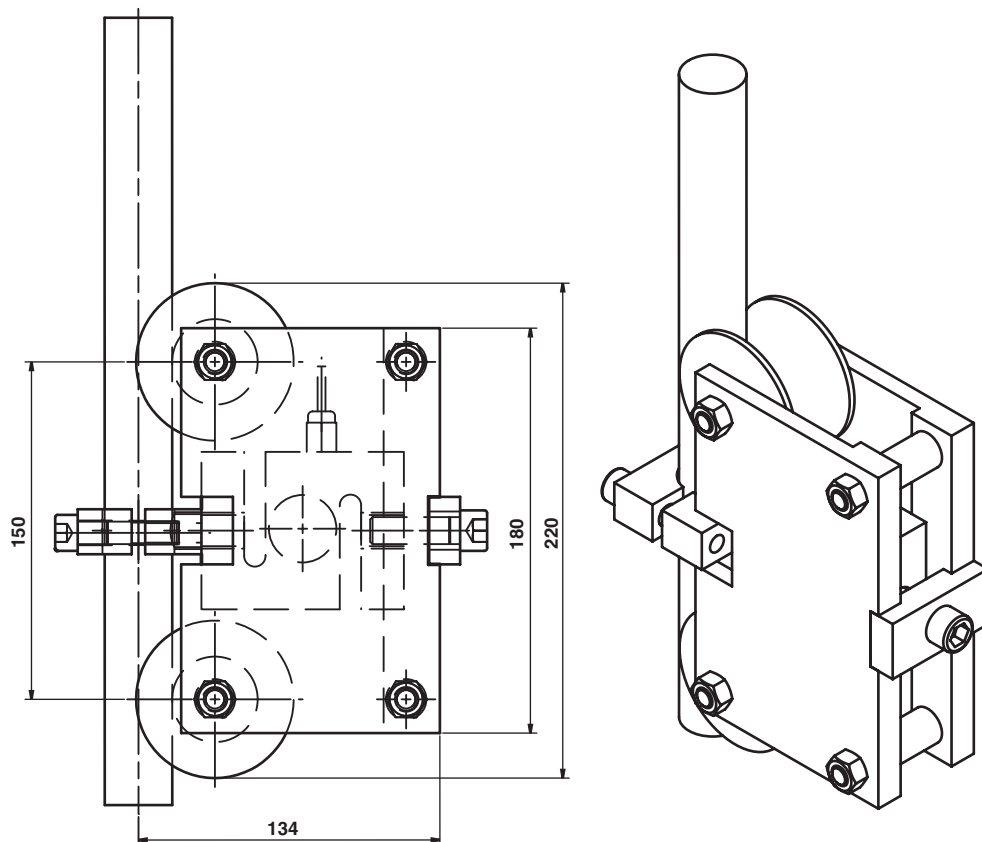

# Rope Tension Transducer

Nobel Weighing Systems Rope Tension Transducer (RTT)



## SPECIFICATIONS

PARAMETER		VALUE	UNIT
Rated load (R.L.)		Application dependent	
Wire diameter*		10 - 36	mm
Non linearity		±2.0	% of R.O.
Repeatability		1	% of R.O.
Input voltage	recommended	10	V DC or AC
	maximum	15	V DC or AC
Input resistance		385±15	W
Output resistance		350±3	W
Rated output (R.O.)		Application dependent	mV/V
Temperature range		-20 to +70	°C
Temperature effect (-10 to +50°C)	on output	±0.003	% of output/°C
	on zero balance	±0.03	% of R.O./°C
Insulation resistance at 200V DC		>4	GW
Material		Plated alloy steel	
Electrical connection		6 m shielded six conductor	
Degree of protection		IP67	

\*Customer specific available on demand.